

CH buffer tanks, not enamelled

SVK



A

**HEAT
PUMP
READY**

Perfect with central heating installation, eg. with co-operation with heat pump.

Most important advantages

Energy class A

SVK buffer tank ensures highest energy class.

- very high thermal insulation class reduces heat losses up to 50%! Comparing to efficiency class C it saves up to 320 kWh annually

High thermal insulation and esthetics

- A class 65 mm insulation, made of polyurethane foam
- esthetic design and resistance to mechanical damage as cylinder's casing is made out of solid ABS material

Unbeatable quality

- products are made of the steel grades selected by our verified suppliers
- each device undergoes leakage tests and coating checks quality control

Easy installation

- CH connections directed up allow for easier connection to the installation of heat pump

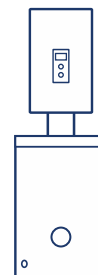

Dimensions

model SVK

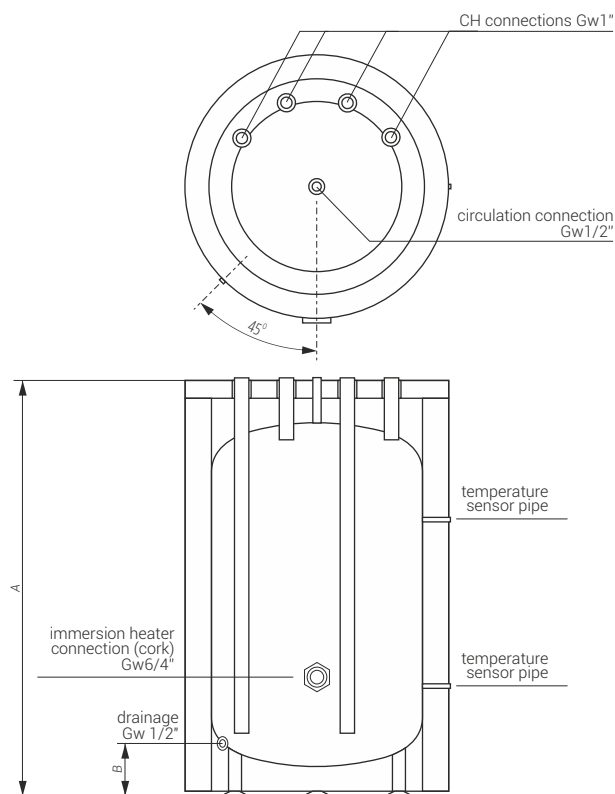

	Średnica (mm)	A (mm)	B (mm)
SVK-100	595	906	127

Additional equipment

Immersion heaters can be installed in the cylinder:

GRW-1,4kW/230V; GRW-2,0kW/230V;
GRW-3,0kW/230V; GRW-4,5kW/400V

Technical data

Type	Storage capacity (l)	Rated pressure (MPa)	Thickness / material / type of insulation **	Stand-by-losses *** (W)
SVK-100	104	0,6 MPa	65/PUR/NR	27

** Insulation: R- removable, NR- not removable

*** In line with EU Commission resolution, no. 812/2013,814/2013.