

ELECTRIC CENTRAL HEATING FLOW BOILER



EKCO.A1



Used product can't be treated as general communal waste. Disassembled appliance has to be delivered to the collection point of electrical and electronic equipment for recycling. Appropriate utilisation of used product prevents potential negative environmental influences that may occur as a result of inappropriate handling of waste.

In order to get more detailed information about recycling this product you should contact the local government unit, waste management service or the shop where this product has been purchased.

Safety instructions

1. Read and strictly follow the installation and operating instructions to ensure a long life and reliable boiler operation.
2. An efficient electrical installation which has been completed in accordance with the binding norms of electric installation.
3. A wet central heating system equipped with appropriate expansion vessel made according to the binding norms of hydraulic installation.
4. A wet central heating system must be flushed before boiler installation.
5. Do not install any barrier fittings (e.g. valves) on the outlet of the safety valve.
6. Boiler must not be installed in a humid place or in a place exposed to the danger of explosion.
7. Boiler installation and all electrical and hydraulic work must be performed by a qualified professional installer only.
8. All installation work must be performed when the power and water supply is cut off.
9. Electric installation should be equipped with residual current protective devices and other solutions which will ensure disconnecting the heater from the source of power (intervals between all their poles should not be less than 3 mm).
10. Do not cut off the power supply between the heating seasons. Despite the knob is set in „OFF” position, the boiler will start the pump every 24 hours for 90 seconds to protect the installation.
11. Do not drain the water from central heating system after the heating season.
12. Before the heating season boiler should be checked by the service point.

This appliance is not intended for use by persons (including children) with reduced physical, sensory or mental capabilities or lack of experience and knowledge, unless they have been given supervision or instruction concerning use of the appliance by a person responsible for their safety.

Children should be supervised to ensure that they do not play with the appliance.

Installation

1. In order to take off the front cover, undo the fixing screws and disconnect the protective wire. For fixing the unit permanently leave free space at the top and bottom for access tool to unscrew the screws.
2. Hang the boiler up in a vertical position on fixing screws with the inlet and outlet pipes to the bottom.
3. Connect the boiler to a central heating system equipped with cut-off valves.
4. Fill the central heating system with a treated water that substantially extends the life of the heating elements.
5. Vent the wet central heating system.
6. Connect a boiler to the electric mains. Boilers of 4 and 6kW are factory preset to work as single phase boilers. If you intend to connect a boiler to the three-phase electrical system, take off the wire set [2].
7. Fix the room thermostat, in accordance with its manual.
8. Connect the room thermostat (by using two wires $2 \times 0,35 \text{ mm}^2$) to the (RT entry) on controller. In order to insert the wires to the clamps, you have to press the switch on the connecting element with a use of a screwdriver.
9. Once you have finished the above procedures, you can start the boiler according to „start-up” section.

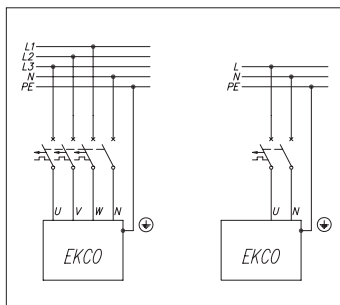
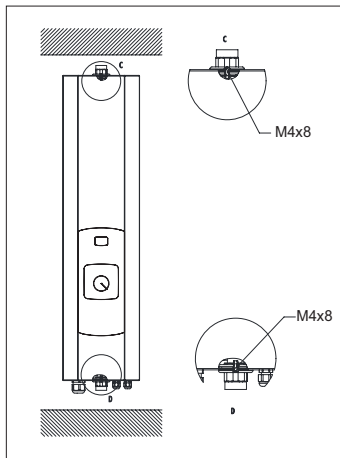

Make sure that the room thermostat connection is a voltage free one!

The RT connection is a voltage free connection! Connecting voltage will destroy the controller.

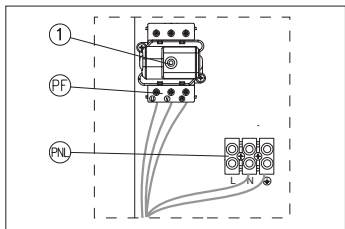

Connection to the three phase system.

- PNL - points of neutral and protective conductor connection
- PF - points of phase conductors connection.
- [1] - temperature limiter (for 4, 6kW boilers, take off the [2] wire set)

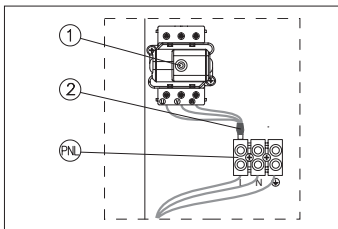

Connection to the single phase system

- PNL - connection points of neutral, protective and phase conductor
- [1] - temperature limiter
- [2] - additional conductor (for single phase system only)

Central heating installation diagram

- PI - manometer
- ZK - cut-off valve
- F - magnetic filter
- RW - expansion pipe
- NW - expansion vessel
- ZT - thermostatic valve
- ZP - passage valve
- G - radiator
- RTP - room thermostat
- ZU - differential pressure relief valve (bypass)
- PO - circulating pump

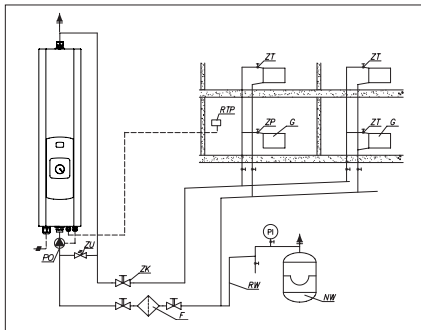

A magnetic filter must be installed on return pipe of central heating installation system (before boiler inlet). The filter must be installed in horizontal position, accordingly to flow direction (see arrow on the filter body), with the magnetic insert chamber to the bottom.

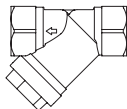

Connection of external appliances

- [3] - RT- Room Thermostat contacts entries
- [4] - Pump- Circulating Pump entry
- [5] - LED- Room Thermostat on, signal
- [6] - Pump LED - Pump on, signal
- [7] - Set up switches
 - a) - „Pump mode” working mode of the pump
 - b) - JP3 unused
 - c) - JP4 unused
- [8] - front panel connection
- [9] - Water - water in boiler signal

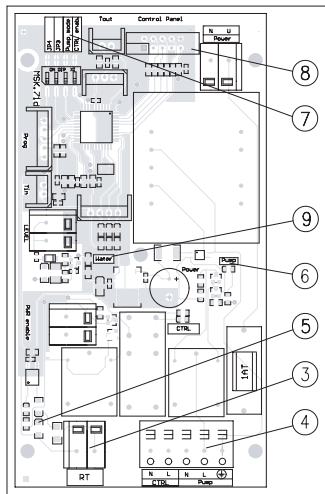

There is a boiler controller to which a number of external appliances can be connected and the controller working modes can be set. Additionally, it signals some modes that help to the initial start up and checking correct operation of the boiler.

1. **A room thermostat** should be connected to the boiler through the RT [3] entries. When the connections are opened, the boiler will recognise that the required temperature in the room is reached. In this case the boiler will switch the heating off. LED [5] on the controller board signals the room thermostat status. The [5] LED indicator illuminates when the thermostat connections are closed.
2. **Pump.** Use the [4] entries to connect a pump. The pump is powered by the fuse (1A delayed 230V) that is situated on the controller board with the use of connector. When the pump is running, the LED indicator [6] is also illuminated.
3. **Choosing the pump mode.** There are set up switches on the control board to control the operating mode of the pump. Setting the switch to „ON” position changing the pump mode to constant work, despite the status of the room temperature connected to RT entry [3]. If the set up switch is in different position, the pump will operate in an automatic mode (i.e when the room temperature reaches the set limit of the room thermostat, the pump will be turned off – RT connection closed).









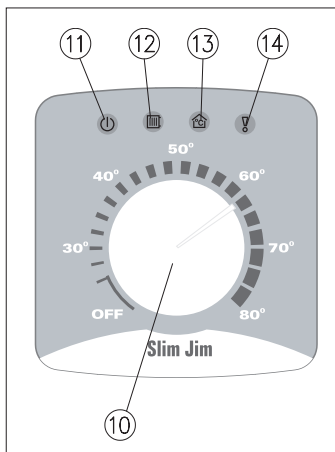























Start-up

1. Connect the circulating pump according to the description in „Connection of external appliances“.
2. Set the pump mode switch to the „On” position.
3. Disconnect a room thermostat from RT entry [3].
4. Set the knob [10] at any temperature e.g 50 degrees .The boiler will start the pump but it will not start the heating.
5. Vent the installation and the pump according to the pump manual.
6. Check the flow in the installation by the use of some proper devices (e.g rotameter) if necessary get rid of the reason of lack of flow.
7. Set the knob [10] in the „OFF” position.
8. Connect the room thermostat and set the pump mode according to „Connection of external appliances“.
9. Turn the boiler on.

Front control panel operation

Control panel is located on the outside boiler cover. It consists of (on-off knob, and temperature control [10], 4 signalling LED indicators [11], [12], [13] green and one [14] red. LED indicators are specified on page 8. In order to start the boiler, set the knob [10] at desire temperature. To switch the boiler off, set the knob [10] in „OFF” position. Switching off procedure will be confirmed by the flashing green indicator [11]. At this time the heating elements are turned off but the pump will still run for 90 seconds. After this time the green indicator [11] goes off and the boiler is fully off.



Signals				
Turn on	Heating	A room thermostat	Fault	
				
light off	light off	light off	light off	Boiler OFF.
				
light on	light off	light off	light off	Boiler on but does not heat, room thermostat does not allow for it.
				
light on	light on	light on	light off	Boiler on and heats, a room thermostat sends heating signal.
				
light off	light off	light off	light on	A failure: no water in the boiler.
				
light off	flashing	light off	light on	A failure of the temperature sensor. If you can start the boiler up (boiler is heating) - a failure of inlet temperature sensor
				
light on	light off	flashing	light off	Maximum inlet temperature is reached, no heat collection from C.H system
				
flashing	light off	light off	light off	Boiler OFF but the pump is still working. Pump will switch off after 90 sec.
				

Technical data

Max. pressure	MPa	0,3
Min. pressure	MPa	0,05
Out flowing water temp	°C	30 ÷ 80
Max water temp.	°C	100
Overall dimensions (height x width x depth)	mm	912 x 203 x 172
Weight	kg	~11
Water connection	mm	22
Safety class		IP 22

Rated power consumption	kW	4	6	4	6	8
Voltage		230V ~		400V 3N~		
Rated current	A	17,4	26,0	3 x 5,7	3 x 8,7	3 x 11,7
Fuse rated current	A	20	32	10		16
Min. connecting wires section	mm ²	3 x 2,5	3 x 4	5 x 1,5		
Max. connecting wires section	mm ²	3 x 16		5 x 16		
Max. allowed network impedance	Ω	0,44	0,39			

Rated power consumption	kW	12	15	18	21
Voltage		400V 3N~			
Rated current	A	3 x 17,3	3 x 21,7	3 x 26,0	3 x 30,3
Fuse rated current	A	20	25	32	40
Min connecting wires section	mm ²	5 x 2,5		5 x 4	
Max connecting wires section	mm ²	5 x 16			

KOSPEL S.A.
ul. Olchowa 1
75-136 Koszalin
tel. +48 94 346 38 08
info@kospel.pl
www.kospel.pl